

*Making Your Life Easier*

AMERICAN-BUILT UTVS AND FUN KARTS





## OUR VISION

At American LandMaster, Making Your Life Easier, is more than just a tag line. It's the primary lens through which we view every decision we make. From designing vehicles, to choosing which vendors to work with, to developing accessories, the first question we ask is, **"does it make the user's life easier?"**

At the end of the day, we want to know your yard cleanup went quicker, your chores were easier, your hunt was more successful, or your weekend was better, because **American LandMaster is Making Your Life Easier.**

## OUR CULTURE

"Corporate responsibility" is a popular term for companies these days. It's used so often that it has lost its meaning. The responsibility seems only to extend to what makes the best headline, or elicits the least amount of scrutiny, because there's no larger directive driving the thinking and decisions. **At American LandMaster we believe we are called to build UTVs and Karts for the Glory of God.**

At the foundation of everything we do is trust. Trust in each other and trust in the Lord. Trust is what allows us to work better as a team, get the right ideas to the table, and why we are comfortable challenging each other to do better. Trust is why we know American LandMaster will succeed for years to come.

## AMERICAN BUILT, AMERICAN OWNED

Too many people think you can't build things in the USA anymore. Worse yet is the thinking that if something is built here it has to cost a lot more than something built overseas. We're here to challenge that thinking.

**American LandMaster UTVs are built from the ground up in Columbia City, Indiana.** We bring in raw, cut steel tubing for the frames, then bend and weld every piece by hand. The frames are powder coated here as well, by our employees, on our powder coat line.

American LandMaster strives to use domestic products whenever possible, because it helps Make Your Life Easier. By working with domestic partners we can keep lead times and freight costs down, passing those savings on to you.

American LandMaster is **AMERICAN BUILT AND AMERICAN OWNED**, because with a name like ours, how could it not be?

# THE BEST COMBINATION OF DURATION AND COVERAGE IN THE INDUSTRY

We build UTVs at American LandMaster with the intention of our customers never needing to use a warranty, but we know things happen. So in the unlikely event that our customers need to exercise their warranty we want to make sure that an unpleasant situation isn't made worse by a tedious, time-consuming, difficult-to-understand warranty process that only serves to further frustrate an already frustrating situation.

**That's why we created the Easy Life Warranty.**

The **Easy Life Warranty** from American LandMaster is a 12-month bumper-to-bumper limited warranty. Does limited sound confusing? It isn't. **As long as you care for your machine like you should, don't wreck it, or crush it, or let it be attacked by unruly farm animals, we're going to cover it.** Except for tires, brake pads, batteries, damage, neglect. That's the limit.

Cable breaks? Covered.

Bearing goes out? Covered.

The engines are covered by their own 3-year warranty by the manufacturer. So for engine issues, we can help get you to the right people.

Everything else, for a year from purchase, we're here for you, with a straightforward protocol to get you back working as quickly as possible. **Because even if you need to use our warranty, we want to be Making Your Life Easier.**

For full warranty details, or to register your warranty, visit [www.AmericanLandMaster.com/warranty](http://www.AmericanLandMaster.com/warranty)

**Don't worry about your warranty coverage. Just buy the unit with the best coverage to begin with.**



	AMERICAN LANDMASTER	MASSIMO	FSUN	ARTIS	Mitsubishi	Kubota	GOVIA
ENGINE WARRANTY (Months)	36	12	24	12	36	12	12
SPECIFIC WARRANTY EXCLUSIONS	3	30	22	18	11	11	10
BELTS	✓	✗	✗	✗	✗	✗	✗
CABLES	✓	✗	✗	INFO UNAVAILABLE	INFO UNAVAILABLE	✗	✗
PLASTIC COMPONENTS	✓	✗	✗	INFO UNAVAILABLE	INFO UNAVAILABLE	✗	✗

The information above was compiled through research on the current coverage and restrictions respectfully offered for each company. Early 2018



**ALL THE PERFORMANCE - NONE OF THE NOISE**

# ELECTRIC VEHICLES

## LS48V

The perception that electric vehicles aren't as capable as their combustion engine cousins may be true for race cars and big rigs, but when it comes to utility vehicles it couldn't be more wrong.

**When we designed the all-electric LS48V we were adamant, it had to perform on level with the rest of our vehicles.**

Concerned about health or stealth? The LS48V is fume-free and silent. So if you're working in an enclosed environment where exhaust fumes could be a hazard, or want silent operation to sneak into the woods on crisp fall mornings, the LS48V fits the bill.

**Unlike some other all-electric models on the market, the LS48V is built on the same frame as the rest of the LandStar UTVs from American LandMaster, meaning virtually the full line of American LandMaster accessories is available for you to maximize the functionality of your LS48V.**



### DIGITAL CONTROLS AND BATTERY

Being alone and out of battery power in a cold, dark woods is no way to spend an evening. We don't want to let your hunt or a hard day of work end poorly because of an inferior power system. That's why every LS48V features six ultra-dependable deep-cell 8-volt batteries to power the 48V motor for silent, fume-free operation. The 500 amp Curtis controller and dual-mode switch allows for speed regulation and improved battery life.



### REGENERATIVE BRAKING

With an electric unit, nothing is more important than battery life. To help improve the life of the battery between charges, the LS48V employs a regenerative braking system. When your foot is on the accelerator it runs the electric motor and draws power from the batteries. While the vehicle is rolling with your foot off the accelerator pedal, coasting down a hill for example, the motor continues to turn and can back-feed the batteries, helping you go further between charges.



## HAUL & TOW

You don't have to sacrifice performance just because you want an electric option. The LS48V can still haul 400 pounds and tow 1,100 pounds.

STANDARD COLORS

RED

GREEN

BLACK

WHITE

UPGRADE COLOR

REALTREE

For full vehicle specs see back of catalog



**WORKBOOTS NOT INCLUDED**

# 2WD VEHICLES

LS350 / LS350DL / LS455EFI / LS477V

There's no one-size-fits-all answer for UTVs, because there's no such thing as standard when it comes to the work you're doing. That's why the 2WD LandStar lineup is so diverse.

**The 2WD lineup features three engine options, and models with and without a locking differential.** There's no need to pay for features you don't need, that's why American LandMaster gives you a model range that lets you find the unit that's right for your situation.

Do you need a vehicle suited for work around the yard or garden? Are you hauling hay and fresh water to the back pasture? Are you looking for something fun to drive around the lake this summer?

**Regardless, American LandMaster has a 2WD model that not only fits your needs, but fits your budget.**



## AFFORDABLE & CAPABLE

With the ability to haul 400 pounds or tow 1,100, there's almost nothing you can't tackle. From feed bags, to firewood, to a bed full of harvest from the garden, LandStar can get it done.



## WEATHERPROOF

Never worry about the elements taking a toll on your cargo area. The poly dump bed is rustproof, weatherproof, and impact-resistant. It'll take what you, or Mother Nature throws at it, without blinking.



## 277CC SINGLE CYLINDER KOHLER

The 277cc LandMAXX engine from Kohler is efficient, but capable. A true workhorse, the 277cc LandMAXX delivers reliable performance without the frills and higher maintenance requirements of competitor engines. Furthermore, the **three-year Kohler warranty** provides the peace of mind that should accompany any vehicle purchase.



## 429CC COMMAND PRO OHV EFI KOHLER

The 429cc LandMAXX EFI engine from Kohler is a new offering for the LandStar series. Kohler has been a pioneer in small engine EFI technology, and their EFI system means improved fuel economy, choke-free starting, and advanced sensor technology that allows the fuel system to optimize engine performance in changing working conditions. The 429cc LandMAXX EFI is backed by a **three-year Kohler warranty**.



## 479CC V-TWIN VANGUARD BRIGGS & STRATTON

The 479cc LandMAXX engine from Briggs & Stratton that has been so popular in our LS550 model, that it is now available in a 2WD platform. Delivering the kind of power and reliability small engine users have come to expect from Briggs, this V-twin is a great choice for those who like the flexibility and tuning options that carbureted engines provide, and is backed by a **three-year Briggs & Stratton Warranty**.



## 2WD VEHICLES

### LOCKING DIFFERENTIAL

Conditions can change in the blink of an eye. The trail you drove in on this morning can become a swampy bog after a downpour. The truth of the matter is that a lot of people don't need a four-wheel drive UTV for everyday use, but that doesn't mean that traction control isn't sometimes a concern. If work or play takes you off the beaten path, LandStar UTVs are available with a locking differential. **Sometimes called a "poor-man's four-wheel drive," the locking differential ensures both rear tires are turning at the same speed to help keep you moving forward.** When traction isn't an issue, leave the differential open, allowing the rear wheels to turn at different speeds to reduce digging and rutting in gravel or on your yard.

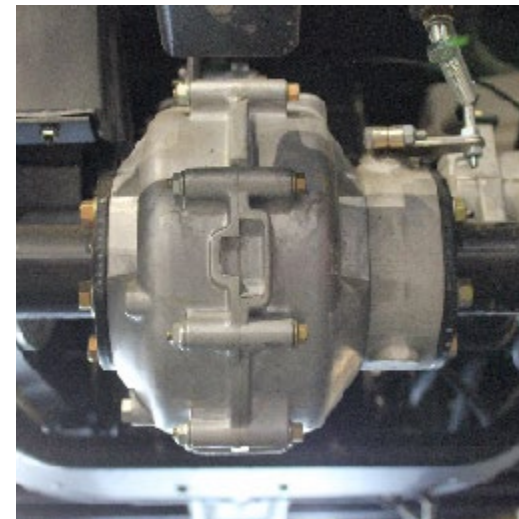





**EXTRA SEATING**

Need to take a couple more people along? Any LandStar UTV can be equipped with the flip-seat conversion, replacing the standard poly bed with a steel bed and rear-facing flip seat. When not being used, the seat folds down into storage, allowing the steel dump bed to be used for cargo.



**ALL STEEL FRAME**

Every LandStar frame is bent and welded in our Columbia City, Indiana facility. We then powder coat every piece before final assembly, meaning our very own quality team is there every step of the way to ensure the structure of every UTV is solid for years of reliable work.



**ADJUSTABLE SHOCKS**

Sometimes a heavy load or rough terrain requires some adjustment to get the most out of your vehicle. Every LandStar UTV is equipped with five-position adjustable shocks that let you customize your suspension. Use softer settings for maximum travel and flexibility, and stiffer settings to stand up to heavy loads.

**ELECTRONIC FUEL INJECTION (EFI) OR CARBURETED?**

Not sure which fuel system is best for you? Both EFI and carbureted systems are capable of years of reliable service, with their own positives and negatives.

Carbureted systems offer more tuning options for those who are inclined and capable. Carbureted systems, however, do require a little more maintenance to ensure peak performance.

EFI systems are more automated. Sensors automatically compensate for engine requirements like choke or fuel mixture. This more technology-reliant system does require more specialized training and equipment when performing work beyond basic service.

	LOCKING DIFFERENTIAL	25" TIRES	277CC KOHLER CARBURETED ENGINE	429CC KOHLER EFI ENGINE	479CC BRIGGS CARBURETED ENGINE
LS350		optional	✓		
LS350DL	✓	optional	✓		
LS455EFI	✓	✓		✓	
LS477V	✓	✓			✓

STANDARD COLORS

RED

GREEN

BLACK

WHITE

UPGRADE COLOR

REALTREE

For full vehicle specs see back of catalog



**HARD WORK MADE EASY**

# 4WD VEHICLES

LS550 / LS550EPS / LS670 / LS677EFI / LS677EPS

Tough terrain, heavy loads, or both, sometimes you need the power and peace of mind that only four-wheel drive can offer. Equipment never breaks down near the shop, and deer are always found in the roughest part of the woods. **When things need done, somehow they always need done in the thickest, most remote and isolated places on the farm.**

That means you need a vehicle that will get you in, but more importantly, get you back out again. The 4WD lineup of LandStar UTVs is designed to meet the needs of the farmer, the hunter, and the landowner.

**American LandMaster provides a unique mix of performance, versatility, and value that can't be found anywhere else in the UTV market.** Explore the 4WD LandStar lineup to see which model we can put to work for you.



## CAPABLE POWER

LandStar UTVs are built for work. Often, that means towing a load or hauling cargo. With a cargo bed capacity of 500 pounds, and towing capacity of 1,200 pounds, there's not much the LandStar 4WD can't handle.

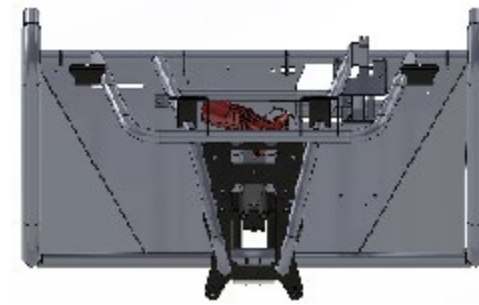

## ELECTRONIC POWER STEERING (EPS)

For 2018, LandStar 4WD models will have a power steering option. When you're hauling a heavy load or towing a trailer, maintaining vehicle control is more important than ever. With electronic power steering, it's easier than ever to maneuver your LandStar in tight spaces or under heavy loads. Every 4WD unit is equipped with a power steering bracket, making the optional kit a bolt-on procedure, while the LS677EPS is equipped with power steering standard.



## 479CC V-TWIN VANGUARD BRIGGS & STRATTON

The 479cc LandMAXX engine from Briggs & Stratton has helped make the LS550 one of our most popular models, and that's not changing for 2018. Delivering the kind of power and reliability small engine users have come to expect from Briggs & Stratton, this V-twin is a great choice for those who like the flexibility and tuning options that carbureted engines provide, and is backed by a **three-year Briggs & Stratton Warranty.**



## 674CC V-TWIN COMMAND PRO KOHLER

Power aplenty in this LandMAXX engine offering. The convenience and low-maintenance of an air-cooled engine, with all the power and torque you could want make the V-Twin Kohler a true work horse. Coupled with the **three-year Kohler warranty**, and the availability of Kohler parts.



## 694CC V-TWIN COMMAND PRO KOHLER EFI

More power, with less to worry about, the 694cc LandMAXX EFI from Kohler is perfectly designed to make your life easier. The EFI system automatically compensates for engine requirements, ensuring peak performance. A **three-year Kohler warranty**, and the peace of mind knowing that Kohler has been a pioneer in small-engine EFI technology makes this engine a solid option for most any application.



# 4WD VEHICLES

## ON-DEMAND 4WD

When you need four-wheel drive, you need it right away. Getting your gear through the swamp or across a muck field to work on a breakdown is no time to get stuck. Times like these are when the on-demand 4WD system in every 4WD LandStar UTV truly shines. Don't wait for difficult terrain to engage the 4WD, engage the system when you start your trip. **When the system senses rear-tire slip, it will automatically engage the front tires to maximize traction.** It doesn't matter if it is work or play that takes you off road, the on-demand 4WD system will keep you moving.

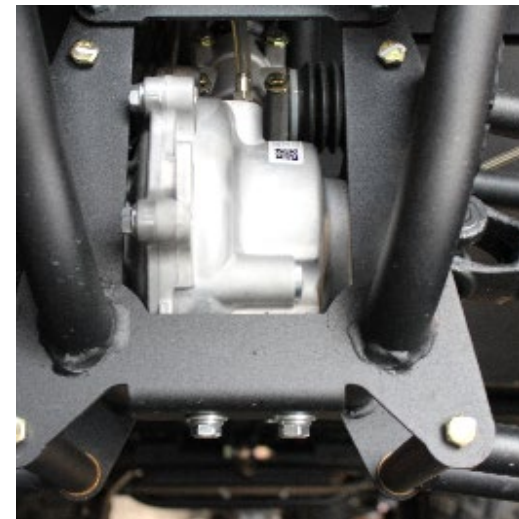



### EXTRA SEATING

Need to take a couple more people along? Any LandStar UTV can be equipped with the flip-seat conversion, replacing the standard poly bed with a steel bed and rear-facing flip seat. When not being used, the seat folds down into storage, allowing the steel dump bed to be used for cargo.



### ALL STEEL FRAME

Every LandStar frame is bent and welded in our Columbia City, Indiana facility. We then powder coat every piece before final assembly, meaning our very own quality team is there every step of the way to ensure the structure of every UTV is solid for years of reliable work.



### ADJUSTABLE SHOCKS

Sometimes a heavy load or rough terrain requires some adjustment to get the most out of your vehicle. Every LandStar UTV is equipped with five-position adjustable shocks that let you customize your suspension. Use softer settings for maximum travel and flexibility, and stiffer settings to stand up to heavy loads.

### ELECTRONIC FUEL INJECTION (EFI) OR CARBURETED?

Not sure which fuel system is best for you? Both EFI and carbureted systems are capable of years of reliable service, with their own positives and negatives.

Carbureted systems offer more tuning options for those who are inclined and capable. Carbureted systems, however, do require a little more maintenance to ensure peak performance.

EFI systems are more automated. Sensors automatically compensate for engine requirements like choke or fuel mixture. This more technology-reliant system does require more specialized training and equipment when performing work beyond basic service.

	LOCKING DIFFERENTIAL	ON DEMAND 4WD	POWER STEERING	479CC BRIGGS CARBURETED ENGINE	674CC KOHLER CARBURETED ENGINE	694CC KOHLER EFI ENGINE
LS550	✓	✓		✓		
LS550EPS	✓	✓	✓	✓		
LS670	✓	✓	optional		✓	
LS677EFI	✓	✓	optional			✓
LS677EPS	✓	✓	✓			✓

STANDARD COLORS

RED

GREEN

BLACK

WHITE

UPGRADE COLOR

REALTREE

For full vehicle specs see back of catalog



**THREE'S A CROWD, FOUR'S A CREW**

# CREW VEHICLES

CREW2 / CREW4 / CREW4X

Does the work you're doing require a few more hands? Maybe your plans for the weekend include a few friends. **Whatever the reason, sometimes you need the flexibility only more seats can offer.**

The LandStar Crew offers all the same capabilities as the rest of the LandStar lineup, while providing seating for four, or six with the optional flip seat conversion.

**The LandStar Crew is available in your choice of two or four wheel drive, but whichever you choose, power steering is standard.**

Take your crew to the beach, the backwoods, or the barnyard, it doesn't matter. The electronic power steering system makes driving the LandStar Crew an enjoyable experience.

**Wherever you're going, whatever you're doing, take a couple friends with you. Take the whole gang, in the LandStar Crew.**

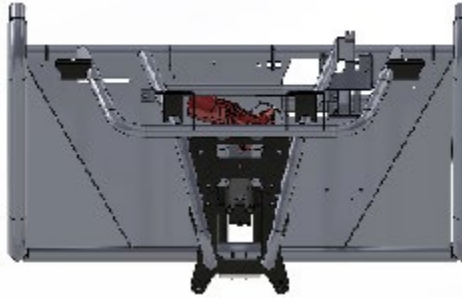

## ELECTRONIC POWER STEERING (EPS)

Electronic power steering makes it easier than ever to maneuver your LandStar in tight spaces or under heavy loads. Every LandStar Crew is built with power steering installed. It doesn't matter if you're loaded down with firewood or friends, power steering makes the driving experience an enjoyable one.



## 674CC V-TWIN COMMAND PRO KOHLER

Power aplenty in this LandMAXX engine offering. The convenience and low-maintenance of an air-cooled engine, with all the power and torque you could want make the V-Twin Kohler a true work horse. Coupled with the **three-year Kohler warranty**, and the availability of Kohler parts, you'll never worry that your LandStar will be out of commission for long.



## ON-DEMAND 4WD

Not all 4WD systems are created equal. LandStar UTVs rely on an on-demand system. There is no need to wait for difficult terrain before shifting into 4WD. Simply engage the 4WD switch as you begin your trip and drive normally on any surface, with none of the additional steering effort or ground rutting associated with traditional 4WD systems. When the system senses rear tire slip, it will engage the front tires to maximize traction. Whether it's work or play that takes you off-road, LandStar UTVs will keep you moving.



## 694CC V-TWIN COMMAND PRO KOHLER EFI

694 V-Twin Command Pro Kohler EFI – More power, with less to worry about, the 694cc LandMAXX EFI from Kohler is perfectly designed to make your life easier. The EFI system automatically compensates for engine requirements, ensuring peak performance. A **three-year Kohler warranty**, and the peace of mind knowing that Kohler has been a pioneer in small-engine EFI technology makes this engine a solid options for most any application.



## 2 & 4WD CREW CAB VEHICLES

### WHEN THE WORKLOAD REQUIRES SOME EXTRA HANDS

We'll help you get the job done

It's not that you can't move livestock or enjoy dove season by yourself, but sometimes it's nice to have company. Other times the work you're doing demands more hands. Why limit yourself to a UTV with room for only one more rider? **American LandMaster Crew models not only offer second row seating, but can be equipped with our steel bed and flip seat conversion, delivering seating for up to six.** Farm, ranch, lake, or woods the LandStar Crew has room for everyone you want or need to take along.







**DRIVETRAIN OPTIONS**

If your need for second row seating is more about fun than work, the LandStar Crew is available in 2WD. Locking differential is standard on all models, should your fun take you into a more off-the-grid location.



**ALL STEEL FRAME**

Every LandStar frame is bent and welded in our Columbia City, Indiana facility. We then powder coat every piece before final assembly, meaning our very own quality team is there every step of the way to ensure the structure of every UTV is solid for years of reliable work.



**CAPABLE POWER**

It doesn't matter if you're hauling friends or feed bags, you need your vehicle to perform. With a total vehicle payload rating for 1500 pounds, you can cruise with the peace of mind that your machine has been engineered and built to handle the load. Dump bed and towing ratings of 400 pounds, and 1,200 respectively mean whether it's a work horse or a party cruiser, your LandStar Crew can take it.

**ELECTRONIC FUEL INJECTION (EFI) OR CARBURETED?**

Not sure which fuel system is best for you? Both EFI and carbureted systems are capable of years of reliable service, with their own positives and negatives.

Carbureted systems offer more tuning options for those who are inclined and capable. Carbureted systems, however, do require a little more maintenance to ensure peak performance.

EFI systems are more automated. Sensors automatically compensate for engine requirements like choke or fuel mixture. This more technology-reliant system does require more specialized training and equipment when performing work beyond basic service.

	LOCKING DIFFERENTIAL	ON DEMAND 4WD	POWER STEERING	674CC KOHLER CARBURETED ENGINE	694CC KOHLER EFI ENGINE
CREW2	✓		✓	✓	
CREW4	✓	✓	✓	✓	
CREW4X	✓	✓	✓		✓



**TIME TO TAKE IT OUTSIDE**

# FUN KARTS

BLACK WIDOW / MARAUDER / CARBIDE

All work and no play makes you...boring. American LandMaster has the lineup of Fun Karts that will help break you out of your work-first mentality. And yeah, the kids will like them too. There's a model for almost every age and experience range, which means the entire family can get in on the fun.

**The American LandMaster lineage goes back to the glory days of fun karts and the storied history of the Manco brand. We continue that horsepower-fueled legacy today with our lineup of off-road karts designed to give kids, and adults, a way to unplug from digital technology for a while and have some fun like we did in the good old days.**

Every kart has seating and safety restraints for two, hydraulic brakes and pedal latch parking brake for safe and efficient braking, and coil-over shocks and rear swing arm for improved ride comfort. All karts are recommended for drivers 13 and up.



## BLACK WIDOW

Don't let the entry-level tag fool you, the Black Widow is built for fun. This two-seater Fun Kart will keep everyone entertained for hours on end. The peppy 136cc engine is capable of speeds up to 24mph, without burning a hole in your fuel budget. The three-position bench seating is adjustable to suit your drivers.



## MARAUDER

If you want a little more space and a little more flash, the Marauder just might be for you. Dual bucket seats provide an added level of comfort, and sliding adjustment for the driver ensures pedals and steering wheel are within reach. Powered by a snappy 208cc engine with a top speed of 24mph, the Marauder is the perfect balance of value and comfort.



## CARBIDE

This is the kart every kid wished they had growing up. Thrilling speeds of up to 39mph are delivered courtesy of the 150cc high-output engine. If you like the idea of having a speed demon to hot-rod with, but also have less-experienced drivers that might not be capable of handling that speed, there is an optional speed reducer module you can purchase to limit the top speed of your kart to 20mph. Dual bucket seats with slide-adjusting driver seat round out the feature and fun-rich Carbide.

For full vehicle specs see back of catalog

# ACCESSORIES

What can we make easier for you? **Accessories are where you make your LandStar model your own, allowing you to customize your vehicle for the exact kind of work, or play, you're doing.** Sound, lighting, cargo management, safety, and customization, we've got accessory options for all of it.

Making things simpler, every LandStar UTV is built using the same frame design, which means in almost every case, the accessories are universally accepted by each and every model. No confusing matrix to sort through to make sure you're buying the right part, no long holds with customer service to get your question answered. **Find the accessory you want, and get to work.**



# MAKE IT YOURS | CUSTOMIZE YOUR UTV

We offer a full range of accessories to personalize and extend the functionality of your vehicle.



LED LIGHTBAR

SIDE MIRRORS

HOOD RACK

2500 LB. CAPACITY WINCH

CUSTOM WHEELS

50" and 60" PLOW BLADES



CUSTOM WHEELS



BLUETOOTH SOUND SYSTEMS



GUN RACKS



ENCLOSURES

These accessories and more are available at your local dealer or at [AmericanLandMaster.com](http://AmericanLandMaster.com)

# FULL VEHICLE SPECIFICATIONS

UTV SPECS	LS48V	LS350	LS350DL	LS455EFI	LS477V	LS550	LS550EPS	LS670	LS677EFI	LS677EPS	
<b>POWER</b>	48V DC 24kw at 70 ft. lbs of torque with 500 amp Curtis controller fed by six 8 volt Trojan T-875 deep cycle batteries	277cc LandMAXX Commercial Power Engine by Kohler 4-Stroke OHV single cylinder with low oil shutdown	429cc LandMAXX Kohler EFI air-cooled OHV single cylinder	479cc VANGUARD 4-stroke pressure lubricated OHV V-Twin with oil pressure warning light	479cc VANGUARD 4-stroke pressure lubricated OHV V-Twin with oil pressure warning light	479cc VANGUARD 4-stroke pressure lubricated OHV V-Twin with oil pressure warning light	674cc LandMAXX Commercial Power Engine by Kohler Command Pro® CH640 rated at 20.5hp 4-stroke OHV V-twin with oil pressure warning light	674cc LandMAXX Commercial Power Engine by Kohler Command Pro® CH640 rated at 20.5hp 4-stroke OHV V-twin with oil pressure warning light	694cc LandMAXX EFI Commercial Power Engine by Kohler Command Pro® ECH650 rated at 21hp 4-stroke OHV V-twin with oil pressure warning light.	694cc LandMAXX EFI Commercial Power Engine by Kohler Command Pro® ECH650 rated at 21hp 4-stroke OHV V-twin with oil pressure warning light.	
<b>SPEED</b>	Up to 22 mph (10 mph in M2 mode)*	Up to 22 mph*	Up to 22 mph*	Up to 22 mph*	Up to 22 mph*	Up to 24 mph*	Up to 24 mph*	Up to 24 mph*	Up to 24 mph*	Up to 24 mph*	
<b>FUEL CONSUMPTION</b>	N/A	Up to 32 mpg*	Up to 32 mpg*	Up to 20 mpg*	Up to 20 mpg*	Up to 18 mpg*	Up to 18 mpg*	Up to 18 mpg*	Up to 18 mpg*	Up to 18 mpg*	
<b>RANGE</b>	Up to 38 miles (in M2 mode)*	Up to 100 miles*	Up to 100 miles*	Up to 100 miles*	Up to 100 miles*	Up to 90 miles*	Up to 90 miles*	Up to 90 miles*	Up to 90 miles*	Up to 90 miles*	
<b>STARTING</b>	Keyed on/off	12V keyed ignition / recoil backup	12V keyed ignition / recoil backup	12V keyed ignition with recoil backup	12V keyed ignition with recoil backup	12V keyed ignition with recoil backup	12V keyed ignition with recoil backup	12V keyed ignition with recoil backup	12V keyed ignition with recoil backup	12V keyed ignition with recoil backup	
<b>BATTERY</b>	N/A	12V / 360 cca utility class	12V / 360 cca utility class	12V / 360 cca utility class	12V / 360 cca utility class	12V / 360 cca utility class	12V / 360 cca utility class	12V / 360 cca utility class	12V / 360 cca utility class	12V / 360 cca utility class	
<b>SPARK PLUG</b>	N/A	NGK BKR5E	NGK BKR5E	NGK BPR6ES	NGK C7HSA	NGK C7HSA	NGK C7HSA	NGK C7HSA	NGK C7HSA	NGK C7HSA	
<b>FUEL CAPACITY</b>	N/A	5.0 gal	5.0 gal	5.0 gal	5.0 gal	5.0 gal	5.0 gal	5.0 gal	5.0 gal	5.0 gal	
<b>ALTERNATOR</b>	Converter / 20 amps	10 amp	10 amp	25 amp	20 amp	20 amp	20 amp	25 amp	25 amp	25 amp	
<b>TRANSMISSION</b>	Direct drive	CVT automatic	CVT automatic	CVT automatic	CVT automatic	CVT automatic	CVT automatic	CVT automatic	CVT automatic	CVT automatic	
<b>TRANSAXLE</b>	H-12 Schafer / DANA gearbox	Gear drive Schafer/DANA oil-filled transaxle	Gear drive Schafer/DANA oil-filled transaxle	Gear drive Schafer/DANA oil-filled transaxle	Gear drive Schafer/DANA oil-filled transaxle	Gear drive Schafer/DANA oil-filled transaxle	Gear drive Schafer/DANA oil-filled transaxle	Gear drive Schafer/DANA oil-filled transaxle	Gear drive Schafer/DANA oil-filled transaxle	Gear drive Schafer/DANA oil-filled transaxle	
<b>DIFFERENTIAL</b>	Open	Open	Locking	Locking	Locking	Locking	Locking	Locking	Locking	Locking	
<b>DRIVE</b>	2 Wheel drive	2 wheel drive	2 wheel drive	2 wheel drive	2 wheel drive	Switch engaged on demand, 4 wheel drive	Switch engaged on demand, 4 wheel drive	Switch engaged on demand, 4 wheel drive	Switch engaged on demand, 4 wheel drive	Switch engaged on demand, 4 wheel drive	
<b>FRONT SUSPENSION</b>	Double A-arms, adjustable shocks with up to 3" travel	Double A-arms, adjustable shocks with up to 3" travel	Double A-arms, adjustable shocks with up to 3" travel	Double A-arms, adjustable shocks with up to 3" travel	Double A-arms, adjustable shocks with up to 3" travel	Double A-arms, adjustable shocks with up to 3" travel	Double A-arms, adjustable shocks with up to 3" travel	Double A-arms, adjustable shocks with up to 3" travel	Double A-arms, adjustable shocks with up to 3" travel	Double A-arms, adjustable shocks with up to 3" travel	
<b>REAR SUSPENSION</b>	Articulated rear swing arm, featuring quad adjustable shocks with up to 3" travel	Articulated rear swing arm, featuring quad adjustable shocks with up to 3" travel	Articulated rear swing arm, featuring quad adjustable shocks with up to 3" travel	Articulated rear swing arm, featuring quad adjustable shocks with up to 3" travel	Articulated rear swing arm, featuring quad adjustable shocks with up to 3" travel	Articulated rear swing arm, featuring quad adjustable shocks with up to 3" travel	Articulated rear swing arm, featuring quad adjustable shocks with up to 3" travel	Articulated rear swing arm, featuring quad adjustable shocks with up to 3" travel	Articulated rear swing arm, featuring quad adjustable shocks with up to 3" travel	Articulated rear swing arm, featuring quad adjustable shocks with up to 3" travel	
<b>BRAKE SYSTEM</b>	6.25" dual rear hydraulic drum with regenerative braking / hand operated parking brake	6.25" dual rear hydraulic drum with hand operated parking brake	6.25" dual rear hydraulic drum with hand operated parking brake	6.25" dual rear hydraulic drum with hand operated parking brake	6.25" dual rear hydraulic drum with hand operated parking brake	Hydraulic disc front, hydraulic drum rear with hand operated parking brake	Hydraulic disc front, hydraulic drum rear with hand operated parking brake	Hydraulic disc front, hydraulic drum rear with hand operated parking brake	Hydraulic disc front, hydraulic drum rear with hand operated parking brake	Hydraulic disc front, hydraulic drum rear with hand operated parking brake	
<b>TIRES</b>	22 x 11 - 10 (front & rear) Terra Trac	22 x 9 - 10 (front) 22 x 11 - 10 (rear)	22 x 9 - 10 (front) 22 x 11 - 10 (rear)	25 x 8 - 12 (front) 25 x 10 - 12 (rear)	25 x 8 - 12 (front) 25 x 10 - 12 (rear)	25 x 8 - 12 (front) 25 x 10 - 12 (rear)	25 x 8 - 12 (front) 25 x 10 - 12 (rear)	25 x 8 - 12 (front) 25 x 10 - 12 (rear)	25 x 8 - 12 (front) 25 x 10 - 12 (rear)	25 x 8 - 12 (front) 25 x 10 - 12 (rear)	
<b>DIMENSIONS</b>	110" L x 50" W x 76" H	110" L x 49" W x 76" H	110" L x 49" W x 76" H	110" L x 49" W x 78" H	110" L x 49" W x 78" H	110" L x 49" W x 78" H	110" L x 49" W x 78" H	110" L x 49" W x 78" H	110" L x 49" W x 78" H	110" L x 49" W x 78" H	
<b>WHEEL BASE</b>	73.5"	73.5"	73.5"	73.5"	73.5"	73.5"	73.5"	73.5"	73.5"	73.5"	
<b>TURNING RADIUS</b>	7.5' inside radius	7.5' inside radius	7.5' inside radius	7.5' inside radius	7.5' inside radius	9.5' inside radius	9.5' inside radius	9.5' inside radius	9.5' inside radius	9.5' inside radius	
<b>DRY WEIGHT</b>	1250 lbs	824 lbs.	824 lbs.	907 lbs.	910 lbs.	1000 lbs.	1015 lbs.	1000 lbs.	1010 lbs.	1025 lbs.	
<b>SHIPPING WEIGHT</b>	1360 lbs.	1041 lbs.	1041 lbs.	1107 lbs.	1110 lbs.	1200 lbs.	1215 lbs.	1200 lbs.	1210 lbs.	1225 lbs.	
<b>BED MATERIAL</b>	Structural foam "Poly Bed" with stake pockets	Structural foam "Poly Bed" with stake pockets	Structural foam "Poly Bed" with stake pockets	Structural foam "Poly Bed" with stake pockets	Structural foam "Poly Bed" with stake pockets	Structural foam "Poly Bed" with stake pockets	Structural foam "Poly Bed" with stake pockets	Structural foam "Poly Bed" with stake pockets	Structural foam "Poly Bed" with stake pockets	Structural foam "Poly Bed" with stake pockets	
<b>BED DIMENSIONS</b>	35.25" L x 41.5" W x 11" D	35.25" L x 41.5" W x 11" D	35.25" L x 41.5" W x 11" D	35.25" L x 41.5" W x 11" D	35.25" L x 41.5" W x 11" D	35.25" L x 41.5" W x 11" D	35.25" L x 41.5" W x 11" D	35.25" L x 41.5" W x 11" D	35.25" L x 41.5" W x 11" D	35.25" L x 41.5" W x 11" D	
<b>BED CAPACITY</b>	9.25 cu.ft. / 400 lbs.	9.25 cu.ft. / 400 lbs.	9.25 cu.ft. / 400 lbs.	9.25 cu.ft. / 400 lbs.	9.25 cu.ft. / 400 lbs.	9.25 cu.ft. / 500 lbs.	9.25 cu.ft. / 500 lbs.	9.25 cu.ft. / 500 lbs.	9.25 cu.ft. / 500 lbs.	9.25 cu.ft. / 500 lbs.	
<b>REAR FLIP SEAT</b>	Available as an option	Available as an option	Available as an option	Available as an option	Available as an option	Available as an option	Available as an option	Available as an option	Available as an option	Available as an option	
<b>TOWING CAPACITY</b>	1100 lbs.	1100 lbs.	1100 lbs.	1100 lbs.	1100 lbs.	1200 lbs.	1200 lbs.	1200 lbs.	1200 lbs.	1200 lbs.	
<b>VEHICLE CAPACITY</b>	900 lbs.	900 lbs.	900 lbs.	900 lbs.	900 lbs.	1000 lbs.	1000 lbs.	1000 lbs.	1000 lbs.	1000 lbs.	
<b>WARRANTY</b>	2 year motor / all other 1 year limited	3 year engine / All other 1 year limited	3 year engine / All other 1 year limited	3 year engine / All other 1 year limited	3 year engine / All other 1 year limited	3 year engine / All other 1 year limited	3 year engine / All other 1 year limited	3 year engine / All other 1 year limited	3 year engine / All other 1 year limited	3 year engine / All other 1 year limited	
<b>ADDITIONAL FEATURES</b>	On-board charger, 3pt lap/ shoulder belts for driver & passenger, 12V/18W LED headlights, 2" rear receiver hitch, welded steel frame, twin 12V auxiliary outlets for accessories, headrests, under seat storage	3pt lap/shoulder belts for driver and passenger, twin 12V auxiliary outlets for accessories, 12V/18W LED headlights, polyurethane powder paint, 2" rear receiver hitch, dump bed, bench seating, welded steel frame, headrests	3pt lap/shoulder belts for driver and passenger, twin 12V auxiliary outlets for accessories, 12V/18W LED headlights, polyurethane powder paint, 2" rear receiver hitch, dump bed, bench seating, welded steel frame, headrests, under seat storage	3pt lap/shoulder belts for driver and passenger, twin 12V auxiliary outlets for accessories, 12V/18W LED headlights, polyurethane powder paint, 2" rear receiver hitch, dump bed, bench seating, welded steel frame, headrests, under seat storage	3pt lap/shoulder belts for driver and passenger, twin 12V auxiliary outlets for accessories, 12V/18W LED headlights, polyurethane powder paint, 2" rear receiver hitch, dump bed, bench seating, welded steel frame, headrests, under seat storage	3pt lap/shoulder belts for driver and passenger, twin 12V auxiliary outlets for accessories, 12V/18W LED headlights, polyurethane powder paint, 2" rear receiver hitch, dump bed, bench seating, welded steel frame, headrests, under seat storage	3pt lap/shoulder belts for driver and passenger, twin 12V auxiliary outlets for accessories, 12V/18W LED headlights, polyurethane powder paint, 2" rear receiver hitch, dump bed, bench seating, welded steel frame, headrests, under seat storage	3pt lap/shoulder belts for driver and passenger, twin 12V auxiliary outlets for accessories, 12V/18W LED headlights, polyurethane powder paint, 2" rear receiver hitch, dump bed, bench seating, welded steel frame, headrests, under seat storage	3pt lap/shoulder belts for driver and passenger, twin 12V auxiliary outlets for accessories, 12V/18W LED headlights, polyurethane powder paint, 2" rear receiver hitch, dump bed, bench seating, welded steel frame, headrests, under seat storage	3pt lap/shoulder belts for driver and passenger, twin 12V auxiliary outlets for accessories, 12V/18W LED headlights, polyurethane powder paint, 2" rear receiver hitch, dump bed, bench seating, welded steel frame, headrests, under seat storage	3pt lap/shoulder belts for driver and passenger, twin 12V auxiliary outlets for accessories, 12V/18W LED headlights, polyurethane powder paint, 2" rear receiver hitch, dump bed, bench seating, welded steel frame, headrests, under seat storage

\* Estimates. Actual top speeds, fuel consumptions and vehicle ranges may vary due to driving conditions, terrain, climate and other extenuating circumstances.

CREW2	CREW4	CREW4X
674cc LandMAXX Commercial Power Engine by Kohler Command Pro® CH640 rated at 20.5hp 4-stroke OHV V-twin with oil pressure warning light	694cc LandMAXX EFI Commercial Power Engine by Kohler Command Pro® ECH650 rated at 21hp 4-stroke OHV V-twin with oil pressure warning light.	
Up to 24 mph*		
Up to 18 mpg*		
Up to 90 miles*		
12V keyed ignition with recoil backup		
12V / 360 cca utility class		
NGK C7HSA		
5.0 gal		
25 amp		
CVT automatic		
Gear drive Schafer/DANA oil-filled transaxle		
Locking		
2 Wheel Drive	Switch engaged on demand, 4 wheel drive	
Double A-arms, adjustable shocks with up to 3" travel		
Articulated rear swing arm, featuring quad adjustable shocks with up to 3" travel		
Hydraulic disc front, hydraulic drum rear with hand operated parking brake		
25 x 8 - 12 (front) 25 x 10 - 12 (rear)		
143" L x 49" W x 76.5" H		
104"		
12.25' inside radius		
1144 lbs.	1254 lbs.	1264 lbs.
1144 lbs. (no crate)	1254 lbs. (no crate)	1264 lbs. (no crate)
Structural foam "Poly Bed" with stake pockets		
35.25" L x 41.5" W x 11" D		
9.25 cu.ft. / 400 lbs.		
Available as an option		
1200 lbs.		
1500 lbs.		
3 year engine / All other 1 year limited		
3pt lap/shoulder belts for driver and passenger, twin 12V auxiliary outlets for accessories, 12V/18W LED headlights, polyurethane powder paint, 2" rear receiver hitch, dump bed, bench seating, welded steel frame, headrests (front & rear), under seat storage (front & rear)		

KART SPECS	BLACK WIDOW	MARAUDER	CARBIDE
<b>ENGINE TYPE</b>	Single cylinder, 136cc, air cooled, 4 cycle	Single Cylinder, 208cc, Air Cooled, 4 cycle	Single Cylinder, 150cc, Air Cooled, 4 cycle
<b>POWER</b>	≈ 4.1 @ 3500	≈ 6.45 @ 3573	≈ 9.0 @ 7500
<b>TORQUE</b>	≈ 7.1 @ 3150	≈ 9.48 @ 3073	≈ 13.0 @ 5500
<b>STARTING SYSTEM</b>	Pull recoil with manual choke	Electric Start with Recoil Backup plus Manual Choke	Keyed Electric / CDI
<b>AIR FILTRATION</b>	Dual element	Dual Element	Single Element
<b>EXHAUST</b>	Muffler with heat shield	Muffler with Heat Shield	Muffler with Heat Shield
<b>FUEL</b>	.67 gal	.67 gal	1.75 gal
<b>OIL CAPACITY</b>	16 oz.	16 oz.	30 oz. 10W40
<b>SPARK PLUG</b>	Torch F6RTC	Torch F6RTC	NGK C7HSA
<b>TRANSMISSION</b>	dual wheel drive CVT	dual wheel drive CVT	Dual Wheel Drive CVT Automatic with Reverse
<b>TIRE SIZE (front / rear)</b>	145/70 - 6 16" x 8" x 7	16 x 6 - 8 / 18 x 9.5 - 8	17 x 7 x 8 / 18 x 9.5 - 8
<b>FRONT SUSPENSION</b>	Double A-arm with damped shocks	Double A-arm with damped shocks	Double A-Arm with Adjustable Coil Over Damped Shocks
<b>REAR SUSPENSION</b>	Swing arm with damped shocks	Swing arm with damped shocks	Swing arm with adjustable coil over damped shocks
<b>STEERING</b>	Rack and pinion	Rack and pinion	Rack and pinion
<b>FRAME TYPE</b>	1" Main frame	1.125" Main Frame	1.125" Main Frame
<b>REAR AXLE</b>	7/8" Hardened alloy steel	7/8" Hardened Alloy Steel	1.33" Hardened Alloy Steel
<b>FINISH</b>	Baked powder coat	Baked powder coat	Baked powder coat
<b>BRAKES</b>	Rear Single hydraulic disc	Rear Single hydraulic disc	8.75" hydraulic disc with parking brake
<b>MAX SPEED</b>	Up to 24 mph	Up to 24 mph	Up to 39 mph
<b>FUEL CONSUMPTION</b>	Up to 50 mpg	Up to 50 mpg	Up to 50 mpg
<b>SEATING</b>	Adjustable bench foam padded	Adjustable driver / fixed passenger	Adjustable driver / fixed passenger
<b>ENGINE STOP SWITCH</b>	On engine and in dash	On engine and in dash	Dual engine stop switch,
<b>RESTRAINT SYSTEM</b>	3-Point shoulder / lap belts with retractor	3-Point shoulder / lap belts with retractor	3-Point shoulder / lap belts with retractor
<b>CUSTOM BARS</b>	1" Full brush bars	1.25" Full brush bars	1.25" Full brush bars
<b>SAFETY</b>	Whip flag / pedal latch style parking brake	Whip flag / pedal latch style parking brake	20 mph speed reduction kit available & whip flag
<b>CURB WEIGHT</b>	268 lbs.	335 lbs.	475 lbs.
<b>WEIGHT (driver, passenger &amp; gear)</b>	300 lbs.	400 lbs.	400 lbs.
<b>SEAT TO PEDALS</b>	33" - 37"	39" - 41"	34" - 39"
<b>WHEELBASE</b>	50"	54.7"	57"
<b>VEHICLE OVERALL</b>	71" L x 47" W x 49" H	82" L x 48" W x 52.7" H	83.2" L x 53.4" W x 53.75" H

*Making Your Life Easier*



 **AMERICAN LANDMASTER** AmericanLandMaster.com | 800-643-7332

**BUILT IN THE USA**  
WITH AMERICAN AND IMPORTED PARTS

Information in this publication is subject to change without notice. Engine specifications are provided by the engine manufacturer and are subject to change without notice. Before operating or riding, always refer to the safety and operating information on the vehicle and in the Operator's Manual. Actual top speeds, fuel consumptions and vehicle ranges may vary due to driving conditions, terrain, climate and other extenuating circumstances. Please travel responsibly, respect the rights of others and avoid sensitive environmental areas such as meadows, lakeshores, wetlands and streams. This information was assembled for worldwide distribution. Not all options may be available in your area. Please consult your local dealer for details. ASW, LLC reserves the right to change specifications, design and price of the products described herein without notice. American LandMaster® and LandStar™ are registered trademarks of ASW, LLC.